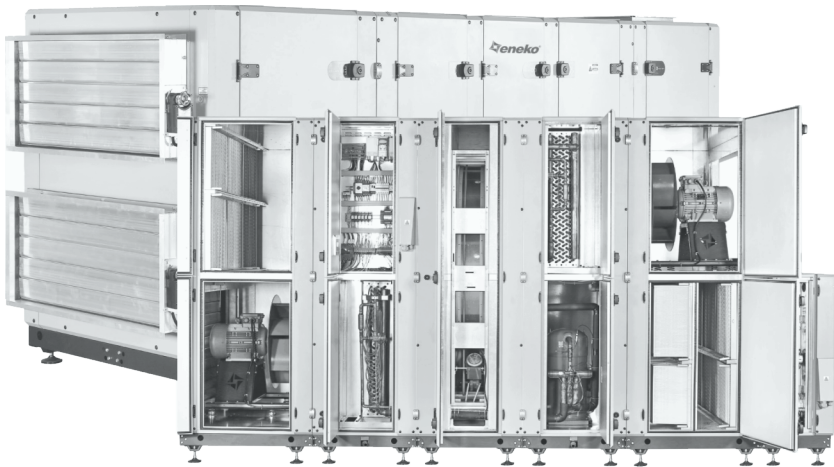




Air Handling Units
(EROVENT/EPOVENT/EHU)

Hygienic Air Handling Units
(EROVENT HGN/EPOVENT HGN/EHU HGN)

Packaged Type Heat Recovery Units With Heat Pump
(EROVENT AC/EPOVENT AC/EHU AC)



Installation & Operation Manual



Introduction.....	Page 1
Warnings & Safety Information.....	Page 2
Check List.....	Page 3
Installation.....	Page 4
Troubleshooting.....	Page 9
Maintenance.....	Page 11
Control System.....	Page 14

INTRODUCTION



Installation & Operation Manual has been prepared and given to customer as a guide for easy installation&operation units manufactured by ENKO A.Ş. The manual contains description of the unit, components and basic informations and recommendations for proper and fail free operation. Please read the instructions and warnings given in this manual before starting installation, operation and maintenance works and keep this manual near the unit, within easy reach of service personnel.



Hygienic air handling units has been designed and manufactured so as to meet the requirements of, DIN 1946/4 & VDI 6022/1 standards.



Any damage, failure or hazard occurred because of use except this purpose is beyond the responsibility of manufacturer.



For technical service and questions, please contact with following information.



+90 232 328 20 80 / 103-152



+90 530 875 65 88



www.eneko.com.tr



servis@eneko.com.tr

WARNINGS & SAFETY INFORMATION



- ◆ This unit has to be used under proper conditions according to its technical specification and design purpose. (Otherwise responsibility belongs to practitioner)
- ◆ Unauthorized personnel must not interfere in unit and/or must not use unoriginal spare parts. (Otherwise responsibility of failure that may occur belongs to practitioner)
- ◆ Do not install this product in a refrigerated warehouse, heated swimming pool or other location where temperature and humidity are significantly different. (Failure to heed this warning may result in electrical shock or malfunctioning.)
- ◆ Unit should not be subjected to excessive vibration and shock while transporting.
- ◆ If the unit is damaged due to any transporting etc. reasons, it should not be mounted.
- ◆ There should be avoided to put any material on to the unit that may cause any damage.
- ◆ Do not install this product in a location where acid, alkali or organic solvent vapors, paints or other toxic gases, gases containing corrosive components or high concentrations of oily smoke are present (Failure to heed this warning may result not only in malfunctioning but also fire, power leakage and electrical shock.)
- ◆ Do not use this product outside the range of its rated voltage and control capacity.



- ◆ If outdoor air is too cold and can cause condensation, pre-heater should be used to prevent.
- ◆ Select an adequately sturdy position for installing the product and install it properly and securely. (The unit can cause injuries in case of fall.)
- ◆ The surface of the unit must be able to carry the weight of the unit.
- ◆ Use electric cables specified in the manual to connect the room control board and check the connection strength (Otherwise fire may occur).
- ◆ Where ducts pass through the building and in the area which is connection with building construction, pay attention that ducts never touch any metal parts and any electrical contact.
- ◆ The outside ducts must be tilted at a gradient (1/30 or more) downwards toward the outdoor area from the main unit, and properly insulated.
- ◆ Gloves should be worn while installation. (Failure to heed this warning may result in injury.)
- ◆ A dedicated circuit breaker must be installed at the origin of mains power supply. This circuit breaker must be provided with a means for locking (lock and key).
- ◆ The body of the unit, the control room panels and cables must be at least 3 meters away from high electro-magnetic field forming equipment or cables.



- ◆ This product must not be disassembled under any circumstances. Only authorized repair technicians are qualified to conduct disassembly and repairs. (Failure to heed this warning may result in fire, electrical shock or injury.)



- ◆ Connect the product properly to the ground. (Malfunctioning or power leaks can cause electrical shock.)
- ◆ Electrical connection should be made by authorized and trained technical personnel.
- ◆ Water connections should be done before the electrical connection is made. Before starting electrical connection, make sure water connection is made tightly.
- ◆ Electrical wiring connections must be made according to the specified electrical wiring diagram.
- ◆ There should not be any changes to the electrical connections that is made at the factory.
- ◆ Cables used in network connection must conform to specified standards and earth connection must be made.
- ◆ A circuit breaker should be placed between the network and unit. The circuit breaker should be selected according to the total power and current value specified on the label.
- ◆ Overcurrent fuse is recommended for the unit.



The installations, which is not available for installation and operation manual, is out of guarantee.

CHECK LIST

In the event of unit failure and pre-commissioning checks to be made are determined as follows; after checking this information, please contact our company in case failure continues.

Controls

√

Make sure that the unit receives power and electrical grounding is made!

Make sure that the electricity cables are drawn from in the correct cross section!
(Please check whether there is heating on cables or not.)

Please check whether the cables in unit control panel are shielded (shielded magnetic field) or not; make sure shielding is grounded. If not, please change them!

Make sure that fresh air and exhaust air filters are clean and they do not block the flow of air!

Make sure there is the connection of drainage on the unit, check any possible clogging in drainage line and clean if necessary!

Please check whether the diameter of the air duct connection of the unit and the diameter of the spigot are the same. If the duct connection is smaller, change it with the correct one.

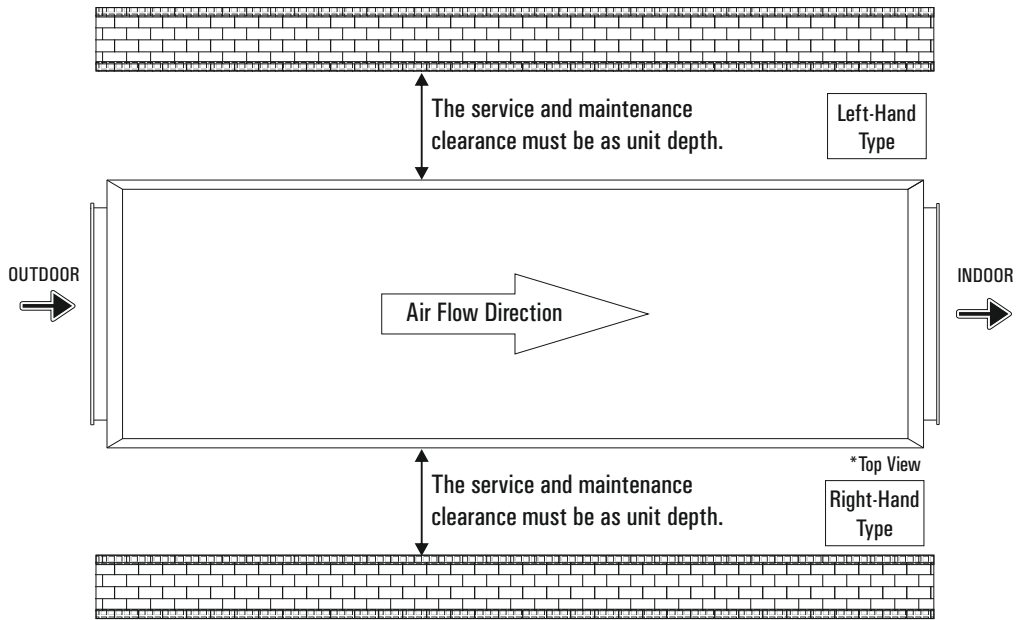
Make sure the electrical connections of the unit are made as suggested on the unit and in this guide, check if there is incorrect connection.

Make sure during the installation of the unit there is enough space for the service and if there is not enough space, re-install again.

In extremely cold climate applications, frost may occur on the exchanger, apply electric heater in fresh air intake section of the unit to get the temperature to -8 °C and above.

After installing the unit, make sure that it does not create an abnormal sound or vibration, if there is, make sure that rubber pads are used.


INSTALLATION



Sufficient clearance must be provided on all sides of unit to remove access panels, fixed panels and in unit equipment. For countries where local regulations take force, appropriate service clearance according local regulations shall be maintained.

Lifting Considerations

- Do not lift the unit when it is windy and while a personnel is working under the unit.
- Use lifting chain as shown below. Lifting chains must be capable of supporting the entire weight of the device.
- Lifting chains may not be the same length. Set lifting chains to balance the device.
- If possible, create a parallel loop straps to the air flow direction.
- For your safety, when unit is lifted up, you may use appropriate equipment method such as belts, straps.
- Determine center of gravity of unit and test it by lifting up about 500 mm. If lifting point is not appropriate, re-determine it to prevent falls. Not lifting the unit properly may cause serious injury even death.

 Failure to follow the instructions above may cause damage of equipment, serious injury, or even death. Subassemblies and parts of unit are equipped as shipped from the factory.

For units that are dispatched as one piece, please place minimum 4 pipes into carrying holes which are located on the unit and affix them to the carrying handle then carry the units as it is shown in **figure a**.

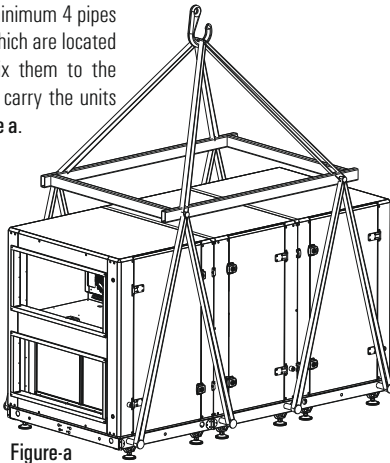


Figure-a

For units that are dispatched as modular, please affix pipes into holes which are located on the units and carry with ropes as it is shown in **figure b**.

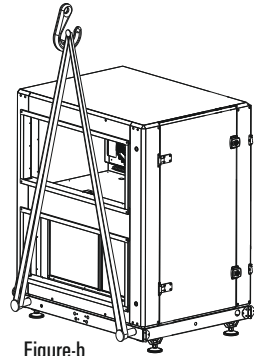
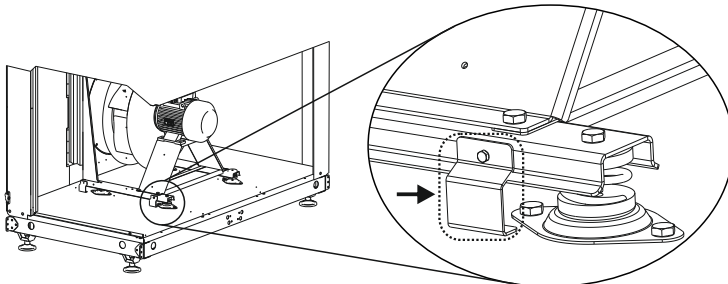


Figure-b

Fan Fixing



Fan fixing parts should be removed before the duct and electrical installation applications.

Assembly of Modular Units

 The following information is available for modular units.

- The modules are moved closer to each other as shown in **Figure 1**.
- The level difference is set (considering surface flat enough). The modules must be equal to each other with the distance from the floor to the floor. Adjustment made by adjustable feet.
- Prepare the installation parts.
- Remove shipping bolts on the mounting surface.
- Assemble the contact surfaces of the unit with the help of sealing.
- Check the seals in between the modules. Change if it damaged.
- Assemble the modules.
- Screw the bolts of connecting parts of the module base frame. (**Figure-2-a**)
- Screw the bolts of connecting parts of the module. (**Figure-2-b**)
- The electrical connection sockets are installed.
- All bolts and nuts placed in an electric panel are assembled.
- If the bolt is in the position where it can be installed, the module assembly is assumed to be uniform then the fixing bolt is installed.

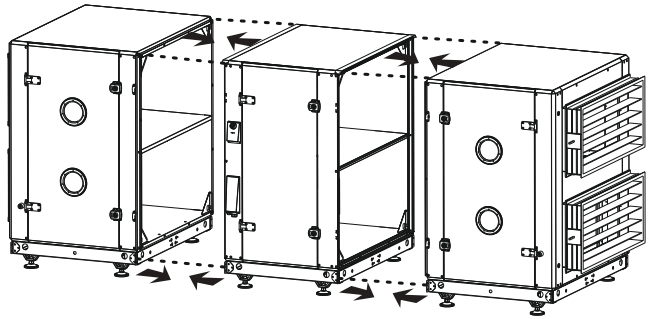


Figure-1

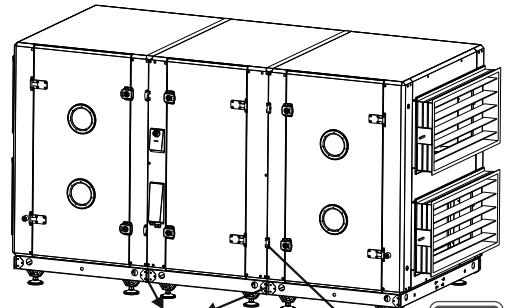


Figure-2

Figure-2-a

Figure-2-b

Rain Protection Cover

- If unit is an outdoor unit, apply silicon to the edges of module connections, underneath and edge of the rain protection cover and the edge of duct connections as shown if **Figure 3**.

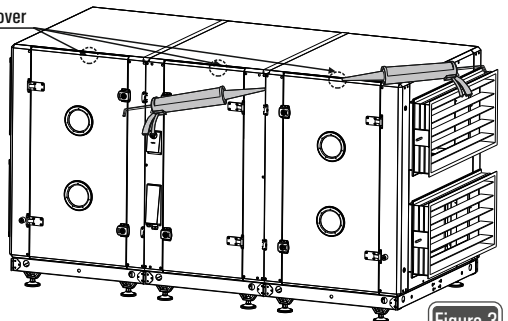


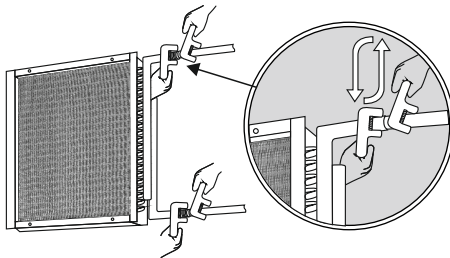
Figure-3

Assembly of Duct Connections

- Ductwork connections should be connected to the unit by flexible duct connectors. Air tightness should be maintained to achieve required air flow conditions. Incorrect ductwork connections can change airflow conditions.
- Make sure that duct connections are connected in correct way using suitable duct sizes. Incorrect assembly directly affects the airflow and sound level.
- Insulate the ductworks or use insulated ductworks.
- Do not allow use elbow joints greater than 90° along with ducting.
- Do not allow use different duct size other than stated in the project.
- Make sure that all ductwork connections are air tight.
- If the ductwork connections are passing through a metal surface wall or metal construction area, make sure that there is ground connection between duct and these surfaces.

Coil Connections

- Use a double wrench while attaching piping to DX / Heating / Cooling coils to prevent damage. It can be damaged fragile copper pipe of the coils while using a single wrench. In this case, unit can be damaged seriously.
- The pipes of coils must be supported separately and insulated thermally.
- Coils, filters and drop eliminators are demounted carefully while connecting piping to coils.
- Please check whether or not to crush on the heat exchanger surface.
- In case you need to replace the coils ensure that the coils meet the requirement of DIN 1946-4 (For hygienic air handling unit)
- Please check the drainage system is available.



Use counter-holding for the connection!


Drainage Connections

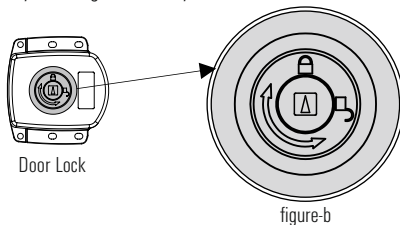
- If there is more than one drain pan, mount siphon to each individual section.
- Never connect the drain pan outlet to drain system without siphon.
- Using only one siphon for all drainage connected to common line may cause overflow in the condensation pan.
- Avoid applications prevent the flow of water in the drain line.
- Drain line should never be on higher level than the condensate pan.

Air Dampers

- Please make sure that the damper flaps are in the closed position in case of power failure during operation.
- Observe whether all damper flaps are in positions suitable for the unit operating principle or not.
- Check that all damper flaps move easily or not.
- Be careful that the damper motor does not force the damper further than the open and fully closed positions.
- Duct load should never place on dampers.

Unit Service Door

- Service doors of the unit are designed to prevent air leakage and to interfere with the unit components. Be careful that the unit doors are locked correctly to make sure there is no air leakage.
- Make sure that the unit doors are locked by inserting the lock key in the middle of the door lock and turning it in the direction of  in figure b.



Inner Casing

- The inner surface of the unit consists of corrosion-resistant galvanized / stainless steel. Also, cleaning and disinfection is easy because the inner surface of the unit is smooth.
- The galvanized / stainless steel design prevents oxidation of the inner surface of the unit caused by humidity or condensation in the air.
- The inner surface of the unit is resistant to disinfectant and similar applications.
- By applying mastic sealant to the gaps at the panel profile joints of the unit, sealing is increased, and dust and dirt accumulation is prevented.

Drop Eliminator

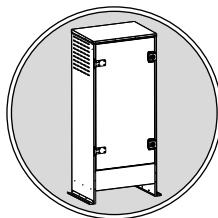
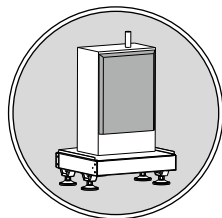
- For the drop eliminator to perform its function, it must be checked whether the position is suitable for the airflow direction or not.
- Check whether the drop eliminator moves smoothly on the slide mechanism.
- Check whether there is a gap between the drop eliminator outlet and the drain pan.

Sound Attenuator

- Check whether there is any tear on the sound attenuator surfaces.
- Check whether there is any crushing on the sound attenuator air guide plates.

Humidifier

- The water supplied in the humidifier shall comply with the microbiological requirements of the drinking-water ordinance.
- In case of shutdown or failure of the air handling unit, the humidifier shall be switched off automatically.
- Make be sure, the humidifier is dried before the shutdown.
- Humidifiers shall be designed so that droplets do not form in the supply air flow downstream of the humidifiers during operation, in the event of a failure of the air handling unit, and when the supply air flow rate is too low or lacking.




Humidifier

TROUBLESHOOTING



Please find in the table below the basic problems that you may encounter with the unit and their solutions. In case of any malfunctions other than those listed below, you should definitely inform ENEKO Technical Service. Please disconnect the power line until the service teams arrives.

Problem	Control
Air Handling unit doesn't work	<ul style="list-style-type: none"> - Make sure there is energy in the power supply and the main switch on the unit panel is turned on. - Make sure the fan connectors are plugged in emergency stop may be pressed, please check. - Fire alarm might be working, please check. - If the device is in auto mode, the time program may not have been made, set the time program.
Air flow is not enough	<ul style="list-style-type: none"> - Make sure that the air dampers installed in the unit or air ducts are open. - Check the duct pressure. If there is a higher pressure loss than specified in the project, the fan or motor may be inadequate. - Check the fan rotation direction. - Check whether the filters are extremely dirty or clogged. - Remove any air leaks from the unit's casing or air ducts.
There is odor in the environment.	<ul style="list-style-type: none"> - Check whether there is enough level of water in the drainage line. - Make sure the drainage line is not connected directly to the sewage line. - Make sure the filters has been replaced on time. - Make sure inside the unit and ducts are clean.
Although filter is not full, there is a filter full alert appears.	Check the inlet-outlet hoses of the differential pressure switch.(Hoses may be disconnected, crushed, or torn)
Sensors differ from what they should be and show instant variability.	Interference may have occurred. Check the unit grounding line. The grounding line may be poor or the ground connection may not be exist. Reinforce the grounding.
Air handling unit works noisy	<ul style="list-style-type: none"> - The air flow may be higher than it should be. Measure the flow and adjust the flow to the appropriate values. - Make sure that the duct sections and conduits are selected according to the air velocity. - Make sure that the fan blade does not rub against the suction nozzle or any surrounding parts. Check the fan balance. - Make sure that the fixing bolts of the fan-motor system are not loose and that the vibration pads work. - Check that the components(exchanger, coil box, filter, damper etc.) inside the device sit vibratively and do not shake. - Make sure that the channels plugged into the unit input-output do not cause sudden contraction and expansion. Use transition channels with an appropriate angle.

Problem	Control
Heating and cooling of the air handling unit has poor performance.	<ul style="list-style-type: none"> - Check the dirtiness of the filter and internal equipment (coils). - Check that the fluid regime from cold and hot fluid providers complies with the project design requirements. - There may not be enough fluid in the cold and hot water battery. The inlet water strainer may be clogged. The control valve motor may be installed loose or locked / malfunction. Please check. - Check for air leaks on the unit or in the duct system. - Check the duct insulation and conduit designs. Check the unit blowing temperature. - If the unit has a rotor, make sure that the rotor is working. Even if it is working information, check it visually. The strap may be broken. <p> After the unit starts, 5-15 minutes (depending on the scenario) is required for the heating-cooling circuit to operate.</p>
Low or high pressure warning in the heat pump systems	<ul style="list-style-type: none"> - The air flow may be absent or insufficient. Check the section on this problem. - Make sure that the components are clean and not clogged. - At high pressure warning: Make sure that the condenser fan is working. - Low pressure warning can occur in the following situations; <ul style="list-style-type: none"> *Expansion valve malfunction *Clogged dryer *Gas leaks *4 way valve malfunction
Motor protection switch malfunction in the heat pump systems	<ul style="list-style-type: none"> - Check the current setting of the motor protection switches. - If the motor protection switch trips continuously, the compressor and condenser fan failures should be checked. - If the motor protection switch is tripping from time to time, fluctuation of the mains voltage should be checked, and the condenser should be cleaned if it is dirty.
Compressor makes noises.	<ul style="list-style-type: none"> - Check that the condenser fan is working. - Make sure that the expansion valve is not clogged. - Dryer may be clogged, replace if necessary.
Compressor does not start	<ul style="list-style-type: none"> - The drive may be off or the fuse has blown. - Make sure that the motor protection current scale is set correctly. - Temperature sensors may be defective, please check it. - Braker / driver, input-output connections may be loose.
Adjustable oil protection switch has a warning	<ul style="list-style-type: none"> - Check the oil level through the sight glass. If it decreases, add suitable oil to the compressor and correct the factors that cause it to decrease. - If the oil level is normal, the oil may be contaminated and blocked the adjustable oil protection switch. - Make sure the cartel resistance is working. - The oil separator may be defective or clogged, if necessary replace it with a new one.
If water accumulates inside or under the unit	<ul style="list-style-type: none"> - Check the sealing of the pipe in the drain line. - Check the direction of the drop eliminator.



TURN OFF all the power switches before the maintenance is performed.
Do not operate the system without the air filter to protect the components of the unit against being clogged.



Please, read the instructions carefully on this manual before operating the system.

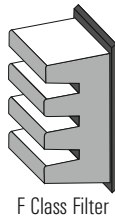
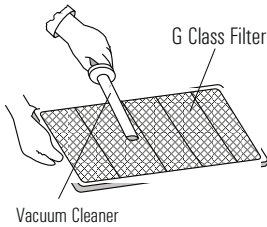
Filter

To clean up G class filters according to EN 779;

- Turn off the unit.
- Remove dirty filters.
- Use a vacuum cleaner to clean the G3-G4 class filters. Use warm water to clean the G2 class filter. Leave to dry after cleaning the G2 class filter.
- Place the filters in the filter slots.
- Close the service cover and be sure it is closed tightly.

To clean up F and M class filters according to EN 779;

- Turn off the unit.
- Remove dirty filters.
- Place new bag filters in the filter slots.
- Close the service cover and be sure it is closed tightly.



Place the F class filters in vertical position.

To clean up electrostatic filter;

- Turn off the unit.
- Remove dirty filters.
- Clean the ionizer and collector to the water you prepare at about 60 ° C together with the oil solvent chemical you add at the rate of 2%. You can clean both parts with a high pressure water gun. Check if the ionizer has a broken ionization wire. Such broken ionization wires can be easily replaced. During washing, check whether there are bent limbs in the collector. If so, carefully fix it with a screwdriver. If an inclined blade comes into contact with another, it may cause a short circuit.
- Leave to dry after cleaning the parts, replace them in the same position before removing them.
- Close the service cover and be sure it is closed tightly.

To clean up activated carbon air filter;

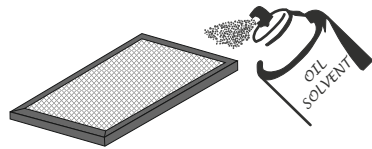
- Turn off the unit.
- Remove dirty filters.
- Place new filters.
- Close the service cover and be sure it is closed tightly.



Activated carbon air filter should have never cleaned with the water. Activated carbon filter should have replaced every 3-6 months with a new one in order to obtain the odor insulation level.

To clean up grease filters;

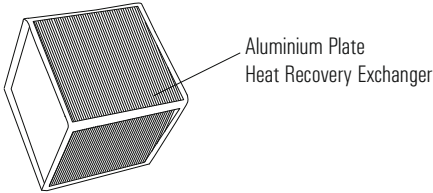
- Turn off the unit.
- Remove dirty filters.
- Clean with oil solvent every fifteen days. Then clean with the hot water. Leave to dry after cleaning the grease filter.
- Close the service cover and be sure it is closed tightly.



Heat Exchanger

For units with aluminum plate heat exchanger;

- Clean heat exchanger with warm water or vapor.
- If necessary, use warm water with natural detergent or soap powder to remove dirt.
- After cleaning, leave the heat exchanger to dry before placing them back in the unit.
- Be sure the screws of service cover are tightened securely and heat exchanger cannot fall out of its slots.



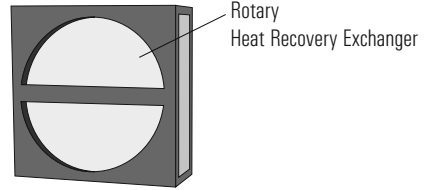
Aluminium Plate
Heat Recovery Exchanger



Cellulosic heat exchanger can be cleaned by using vacuum.

For units with rotary heat exchanger;

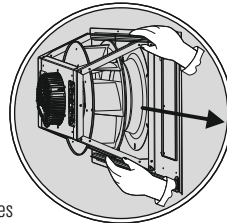
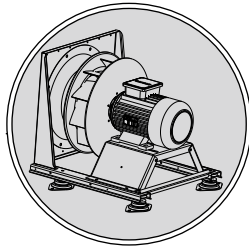
- Turn off the power of the unit.
- Remove the electrical connection of rotary heat exchanger.
- Remove rotary heat exchanger carefully out of the unit.
- Clean fins of storage medium with compressed air.
- Check tension of the drive belt and be sure the belt is running properly.



Rotary
Heat Recovery Exchanger

Fan

- Turn off the power of the unit.
- If the fan connector connection is available, disconnect it first.
- Remove the fan out of the unit carefully.
- Clean the fan with vacuum cleaner.
- Clean the dirty areas of the fan with warm water with natural detergent or soap powder.
- Dry wet surfaces to prevent corrosion on metal surfaces.
- Place cleaned fan in the slots.



Fan Modules

Service Doors

- All unit service doors have leakproof gaskets.
- Make sure that there are leakproof gaskets on unit service doors.
- Always replace when the leakproof gaskets are worn or damaged.

Coils (Heating/Cooling/Run Around Coil/DX)

- It should be checked once every 6 months whether there is any dust accumulation and leakage (leakage) on the air inlet side of the coils.
- In the return section of the coils, water condensation can be seen. It must be checked if the condensate drain is working or not.
- If water freezes in the pipes inside the battery, the pipes will be seriously damaged. Therefore, if there is a danger of freezing in the battery, antifreeze should be added to the circulation water or partial water circulation should be provided in the pipes if the battery will not be operated for a short time.
- If there is serious contamination in the coils, the coil parts should have disassembled and cleaned with compressed air or water in the opposite direction of the air flow.

Sound Attenuators

- No maintenance is required for the sound attenuators mounted on indoor units. However, 2 times a year maintenance is recommended for sound attenuators mounted on outdoor units. If the sound attenuators are exposed to excessive moisture and some chemicals, the the sound attenuator maintenance is recommended more frequently.

Lead Eliminators

- Lead eliminators should not be treated with bare hands. Disposable gloves should be used when handling lead eliminators.

UV Lamps

- UV lamps are used embedded in the panel to prevent dust-dirt accumulation on the inner surface. Replace the bulb during each annual service and maintenance.

Drop Eliminators

- Droplet Eliminator is made of galvanized coated steel / stainless steel and can be completely withdrawn and disassembled. For easy cleaning it is possible to take out all blades by pulling out.

Maintenance Period

Every year;

- Check tension of the drive belt and be sure the belt is running properly (for units with rotary type heat exchanger)
- Paint the exterior surface of casing to prevent corrosion on metal surfaces of the unit.
- Clean fan propeller and fan shaft of the fan.
- If the unit has drain pan, check and clean the drain pan.
- If the unit has damper, check the connection of damper, set screw and rigging.
- Check all electrical connections and isolation.
- Check if there is any damaged cable connections.
- Check if there is any damaged on all gaskets around door and buffer. Check the situation of all isolation materials.
- Check all connections to prevent fracture and leakage, and if there is any repair it.

Every 3-6 months;

- Clean or change clogged or dirty filters. If the pressure drop of a bag filter is higher than 300 Pa, change the bag filter.
- Check all electrical connections.
- Check the accumulated dirt on coils.
- If the unit has damper, clean damper and its components.



Clean up the heat exchanger every two years.

System Connection

- 1- Cut the gaskets in cable connection hole from the center.
- 2- Pass the on/off switch cables through the cable connection hole.
- 3- Connect the main power cable and ground wires to the terminals in the junction box.
- 4- Use cable tie to hold the cables tightly.
- 5- After making cable connections, insulate the cable connection hole against entering water and impurity.


 Make sure that the air handling unit is properly grounded  according to the local regulations.

Considerations During Electricity Network Connection

- 1- Electrical connection must be done by an authorized personnel.
- 2- Drain pipe connection should be done before making the electrical connection and please start electrical installation after being sure that insulation is ensured.
- 3- All kinds of safety measures should be taken by the technician during installation.
- 4- Electrical wiring must be done according to the specified electrical diagram. Any electrical connection which is made by the factory should not be changed.
- 5- Cables to be used during network connection must conform with the specified standards and should be connected to a grounded power supply.
- 6- A circuit breaker should be placed between the unit and network. Circuit breaker must be selected according to the total power and current value specified on the unit's nameplate.
- 7- Over current protection is recommended for the units.




 There are two switch box on the unit. You need to make cabling for each switch box separately.

Automation Cable Color Standard

NO	ELECTRICAL PROPERTIES	FUNCTION
1	R ~	GRAY CABLE
2	S ~	BROWN CABLE
3	T ~	BLACK CABLE
4	NEUTRAL	BLUE CABLE
5		YELLOW / GREEN CABLE
6	CONTROL SIGNAL 1	BLACK CABLE (230 VAC)
7	CONTROL SIGNAL 2	RED CABLE (24 VAC)
8	24 VAC	RED CABLE
9	24 VAC GO	WHITE CABLE
10	24 VDC +	RED / WHITE CABLE
11	24 VDC -	BLUE / WHITE CABLE
12	4-20 mA / 0-10 V	YELLOW CABLE
13	NTC 10k / Pt1000...	ORANGE CABLE
14	NC / NO DRY CONTACT	GREEN CABLE

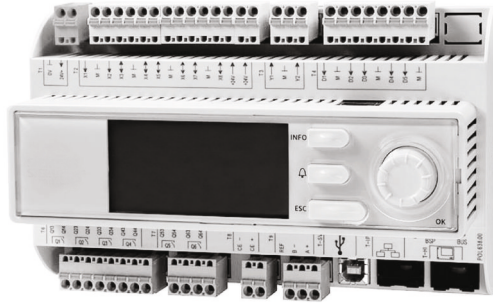
Control Panels

Using on the air handling units control panel types and descriptions are indicated below. The control panels are used optional on the air handling units.

Control Panel Type	Control Panel Descriptions
 <p data-bbox="260 609 460 638">Type-1 (Internal Display)</p>	<ul style="list-style-type: none"> - Internal display on the PLC - IP 20 protection class (EN 60529) - There is no need for any external communication display due to the provided internal display on the PLC.
 <p data-bbox="260 842 465 871">Type-2 (External Display)</p>	<p>Hand Panel 1: Wall-mounted type, IP 65 protection class for only front side of panel, Max. 50 m communication ability</p> <p>Hand Panel 2: Magnet type, IP 65 protection class for whole panel, Max. 50 m communication ability</p>
 <p data-bbox="260 1066 465 1094">Type-3 (External Display)</p>	<ul style="list-style-type: none"> - Magnet type, - IP 31 protection class, - Max. 700 m communication ability

Control Panel - Keypad Explanations

■ Type-1 Control Panel (Internal Display)



Type-1 (Internal Display) Control Panel

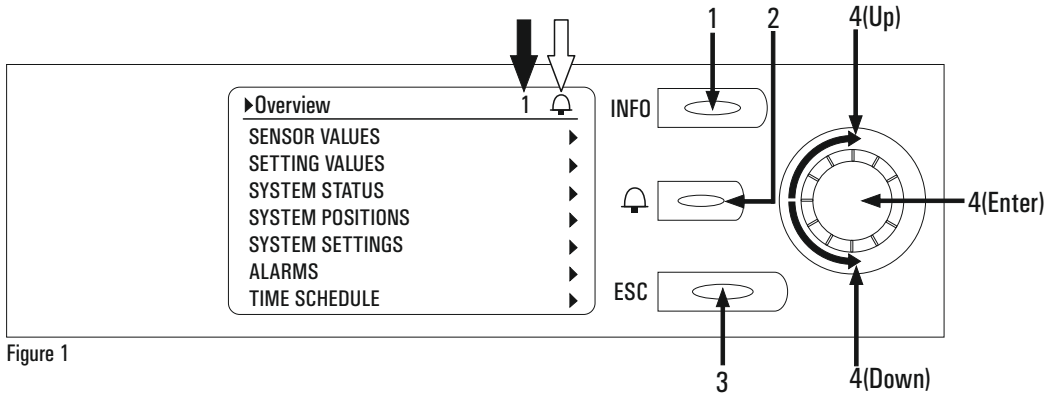


Figure 1

1. **Info:** It allows you to enter the account menu. When the user password is entered as "1000", the system is entered with the user account. After login, the service page will be active on the bottom line in the main menu. The user can access the service menu from this page.
2. **Alarm** : This is the alarm key that displays you malfunctions in the system.
3. **ESC:** This is the exit key that allows you return to the previous menu.
4. **Up/Down:** It is used to turning between the lines and change set values.
5. **Enter:** It's the confirmation key. It allows the changes to be saved.



"1" Indicates the number of rows on the page where the selected row is located.

This symbol indicates malfunctions in the system. If there is a fault in the system, the bell starts to swing. If there is no fault, it doesn't swing.

Control Panel - Keypad Explanations

■ Type-2 Control Panel (External Display)



Type-2 (External Display) Control Panel

■ Control Panel Dimensions

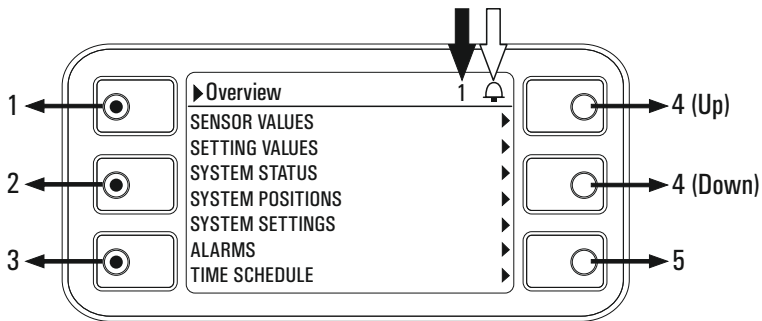
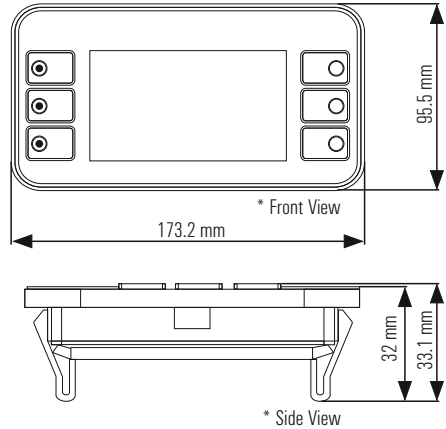


Figure 2

1. **Info:** It allows you to enter the account menu. When the user password is entered as "1000", the system is entered with the user account. After login, the service page will be active on the bottom line in the main menu. The user can access the service menu from this page.
2. **Alarm** : This is the alarm key that displays you malfunctions in the system.
3. **ESC:** This is the exit key that allows you to return to the previous menu.
4. **Up/Down:** It is used to turning between the lines and change set values.
5. **Enter:** It's the confirmation key. It allows the changes to be saved.



"1" Indicates the number of rows on the page where the selected row is located.

This symbol indicates malfunctions in the system. If there is a fault in the system, the bell starts to swing. If there is no fault, it doesn't swing.

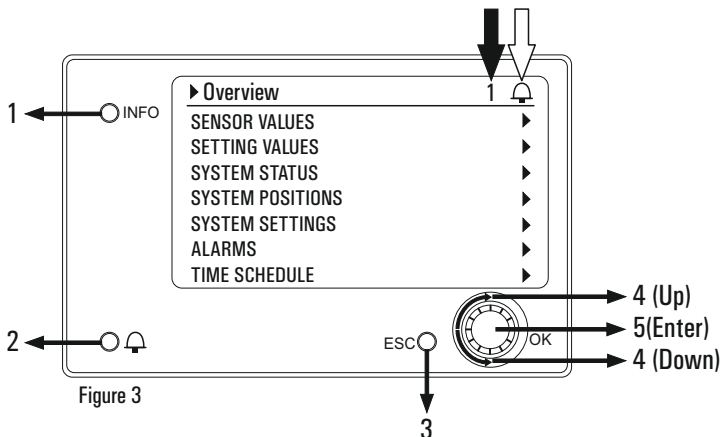
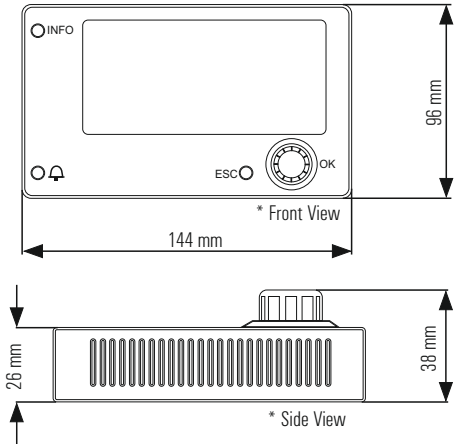
Control Panel - Keypad Explanations

■ Type-3 Control Panel (External Display)



Type-3 (External Display) Control Panel

■ Control Panel Dimensions



1. **Info:** It allows you to enter the account menu. When the user password is entered as "1000", the system is entered with the user account. After login, the service page will be active on the bottom line in the main menu. The user can access the service menu from this page.
2. **Alarm** : This is the alarm key that displays you malfunctions in the system.
3. **ESC:** This is the exit key that allows you return to the previous menu.
4. **Up/Down:** It is used to turning between the lines and change set values.
5. **Enter:** It's the confirmation key. It allows the changes to be saved.



"1" Indicates the number of rows on the page where the selected row is located.

This symbol indicates malfunctions in the system. If there is a fault in the system, the bell starts to swing. If there is no fault, it doesn't swing.

Control Panel Displays and Descriptions

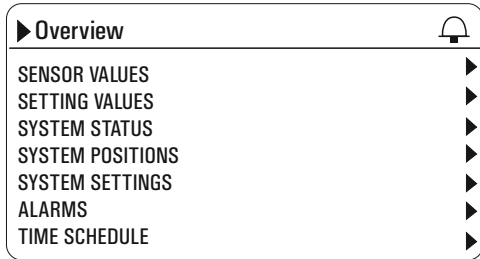


Figure 1

Set and tracking values are divided into pages for easy access. As shown in Figure 1, when the "Enter" key is pressed on the line indicated by the "►" mark, it goes to the related page.

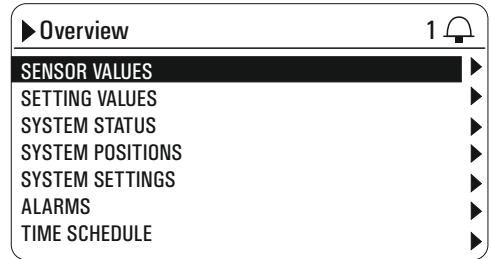


Figure 2

If the background of the line is black as shown in Figure 2, it means that the line is selected. With the "Up/Down" functions, you can switch between the lines. If the entire line is black, then that line has a changeable value. The value is selected with the "Enter" function and the value is changed with the "Up/Down" keys.

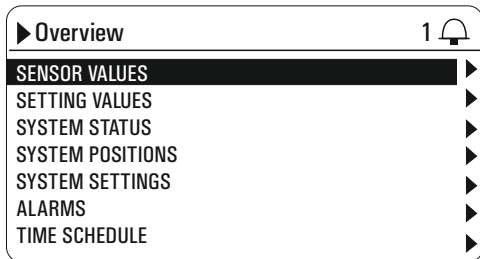


Figure 3

When the "Enter" key is pressed on the 'SENSOR VALUES' line as shown in Figure 3, it goes to the page that the sensor values (see Figure 4) are specified.

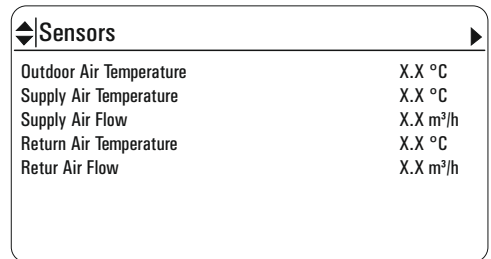


Figure 4

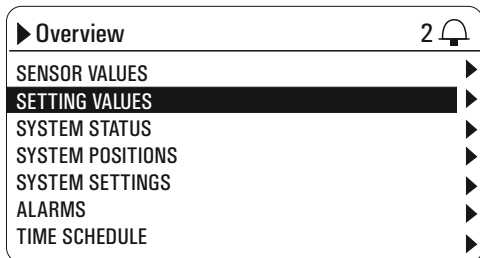


Figure 5

When the "Enter" key is pressed on the "SETTING VALUES" line as shown in the Figure 5, it goes to the page that the setting values (see Figure 6) are specified.

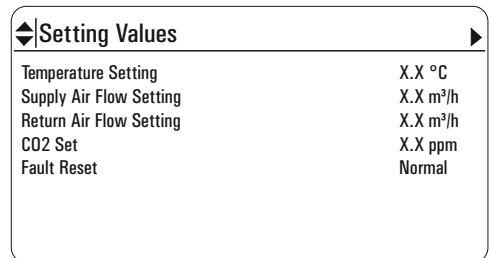


Figure 6

Control Panel Displays and Descriptions

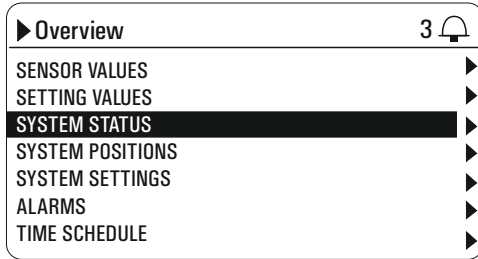


Figure 7

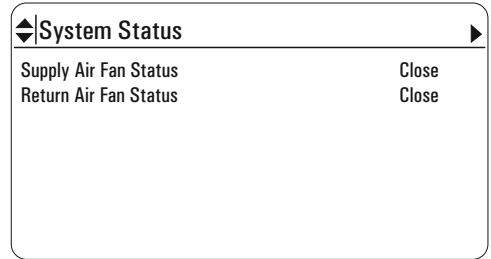


Figure 8

When the "Enter" key is pressed on the "SYSTEM STATUS" line as shown in the Figure 7, it goes to the page that fans open or close status can be monitored. (see Figure 8)

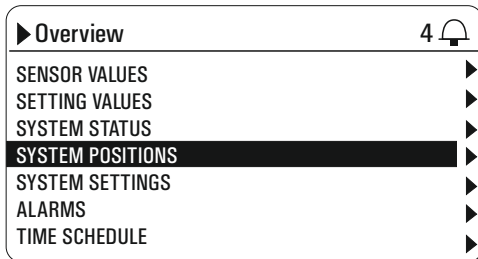


Figure 9

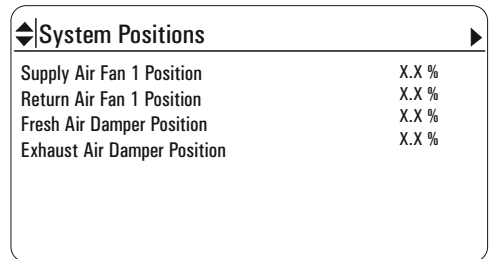


Figure 10

When the "Enter" key is pressed on the "SYSTEM POSITION" line as shown in the Figure 9, it goes to the page that the speeds and positions of the unit can be monitored. (see Figure 10).

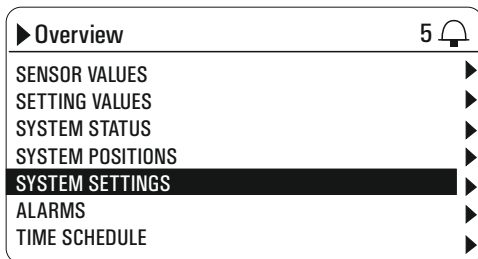


Figure 11

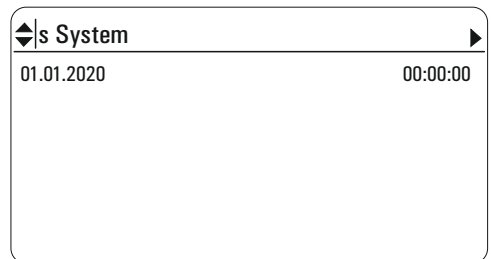


Figure 12

When the "Enter" key is pressed on the "SYSTEM SETTINGS" line as shown in the Figure 11, it goes to the page that date and time settings of the unit can be adjusted. (see Figure 12). For each variable (day / month / year), adjustment can be made using the "Enter" and "Up / Down" direction keys. After each set change, the next key is automatically selected when the "Enter" key is pressed. (see Figure 13 and Figure 14)

Control Panel Displays and Descriptions

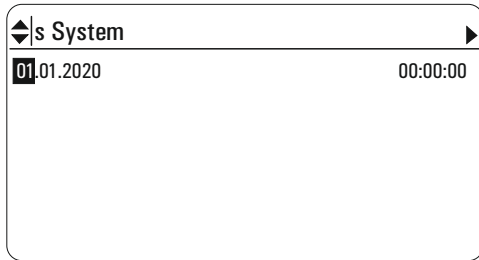


Figure 13

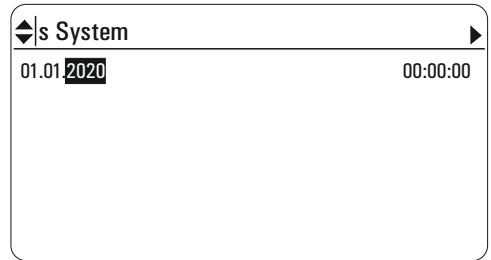


Figure 14



If the system's date and time keeps up to date, time program runs right and failure dates can be monitored.

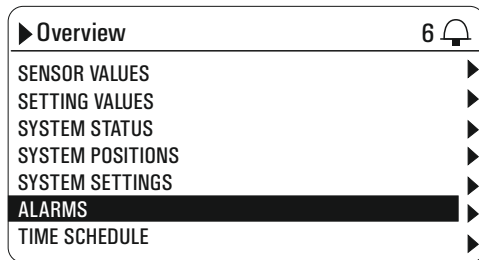


Figure 15

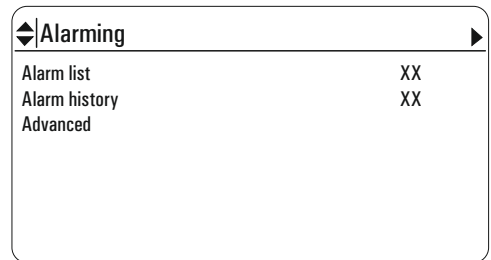


Figure 16

When the "Enter" key is pressed on the "ALARMS" line as shown in the Figure 15, it goes to the page that alarm list, alarm history etc. informations can be monitored. (see Figure 16).

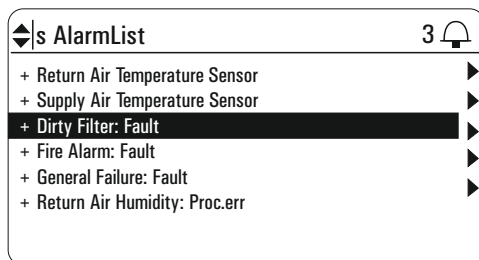


Figure 17

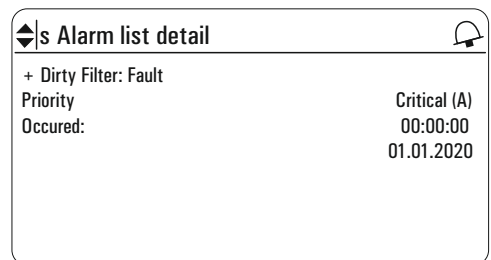


Figure 18

For example, when the "Enter" key is pressed on the "Dirty Filter: Fault" as shown in the Figure 17, it appears alarm details as shown in the Figure 18. If the unit's time and date is adjusted on the "SYSTEM SETTINGS" menu, you can see the time of occurrence of the alarm correctly on the screen.

Control Panel Displays and Descriptions

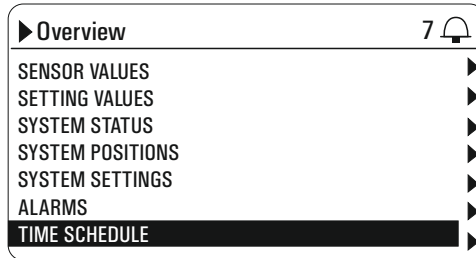


Figure 19

When the “Enter” key is pressed on the “TIME SCHEDULE” line as shown in the Figure 19, it goes to the page that can be adjusted weekly time schedule. (see Figure 20).



You must be logged in to the system with the user account from the password menu for time settings.

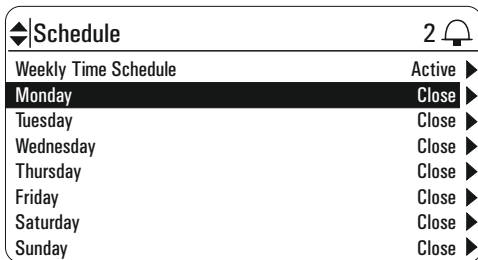


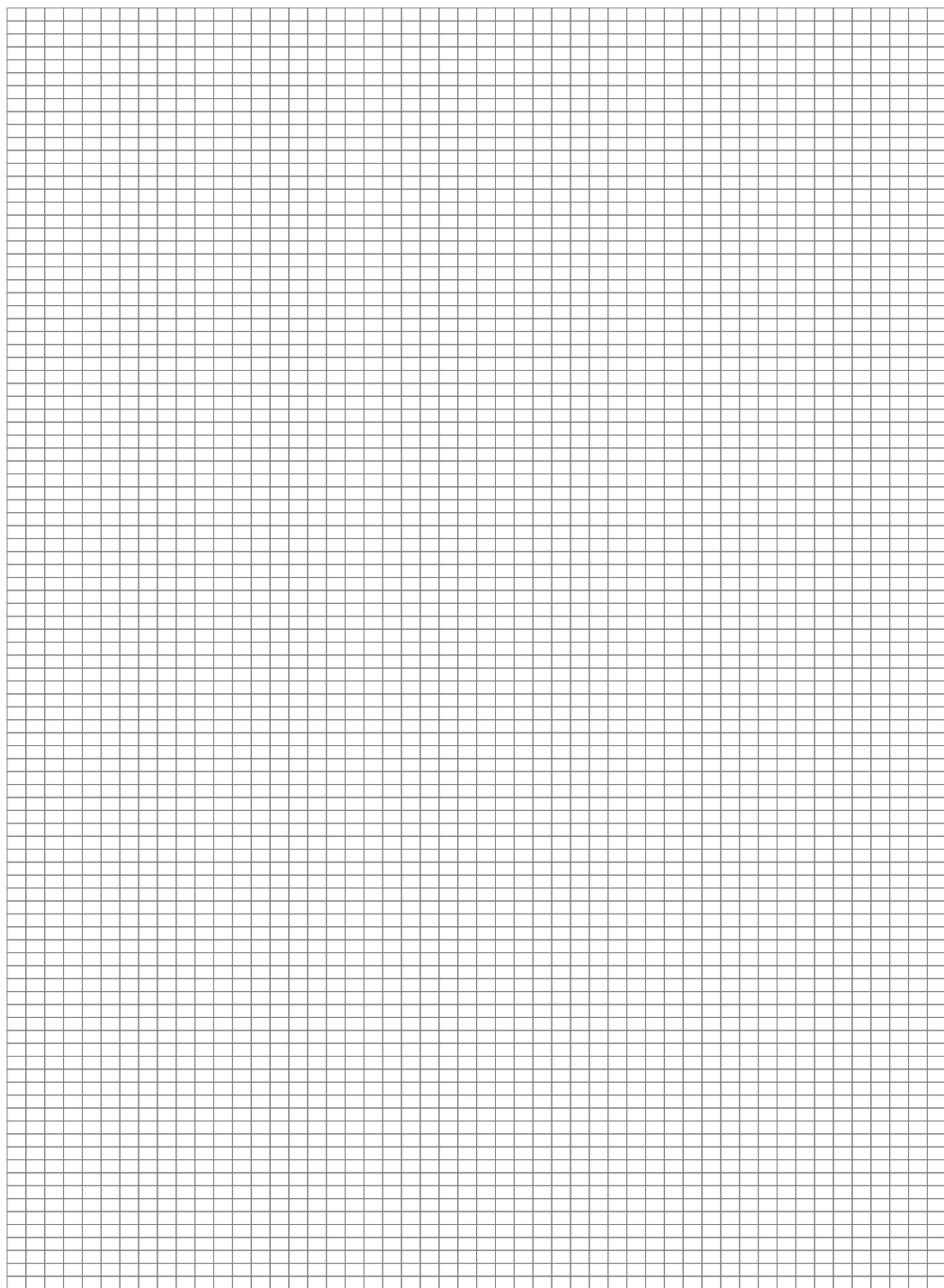
Figure 20

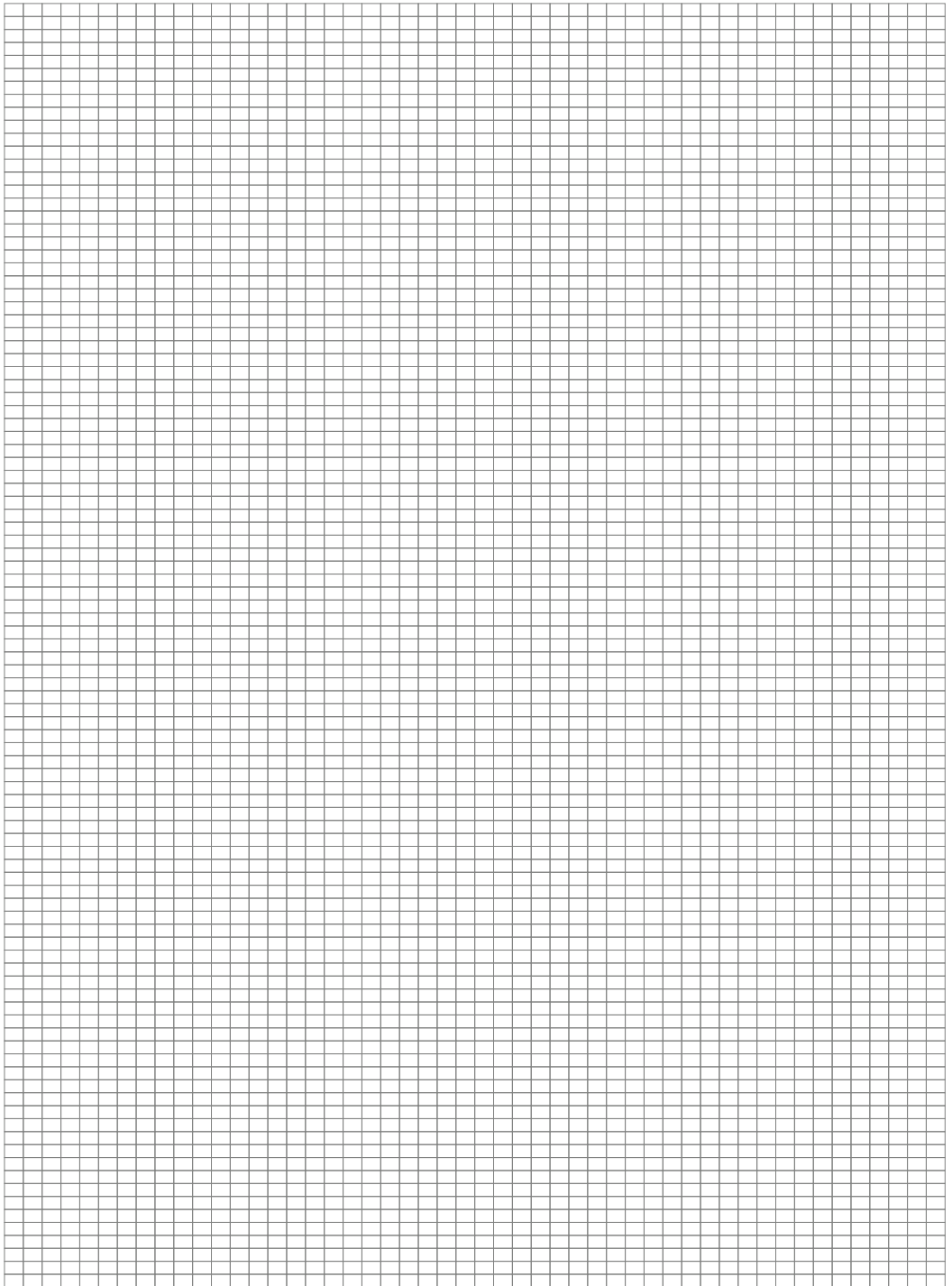
The start time and end time can be adjusted during the day by pressing the “Enter” key onto the days in the “Weekly Time Schedule” page as shown in Figure 20.

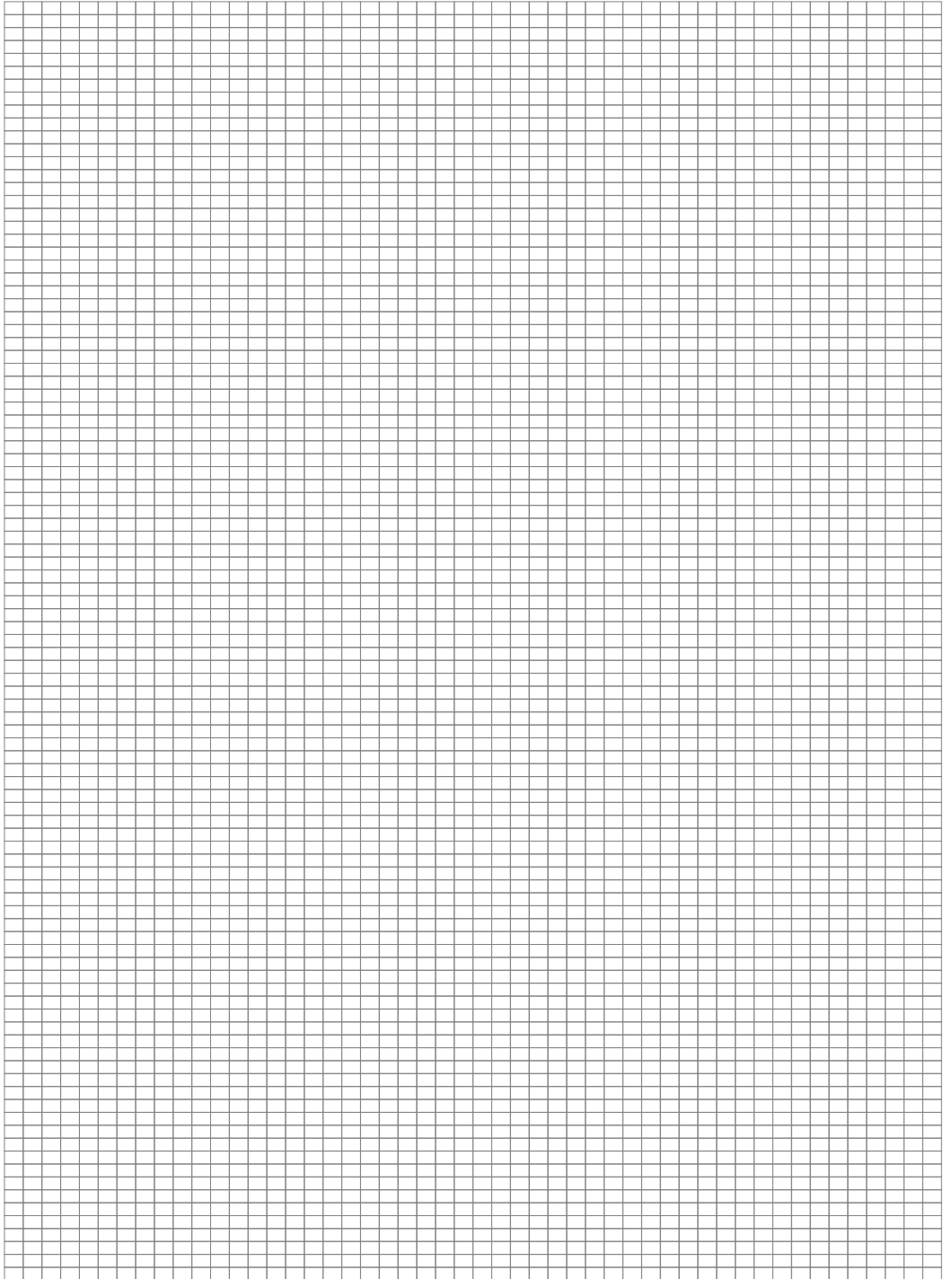


Figure 21

As shown in Figure 21, the time schedule starting time must be adjusted “Time 1”. System date and time which can be set at the settings page reads “Value 1” as system command after starting time passes “Time 1”. Likewise, system date and time which can be set at the settings page reads “Value 2” as system command after closing time passes “Time 2”. The system run command must be selected for “Value 1”. For example, “Open”, “Heating” or “Cooling” etc. After reading the value in “Value 1” the system runs until the closing time according to the command entered. The system shutdown command “Value 2” must be kept “Off” position to shut down the system.









Warranty Certificate

- * If the unit is used according to the instructions given in user manual and interfered in only authorized technical service that we authorize about any maintenance and repair reasons, all spare parts will be under warranty for 2 years against material, labor and production faults except motor components.
- * Identifying of parts replaced and determining troubleshooting technical procedure applied, will belong to our company.
- * After ex-works of goods, all faults during loading, unloading and shipment will be out of guarantee. If a falsify has been made on documents or any falsify and changing have been made on serial number, goods will be out of guarantee.

Terms of Guarantee

1. Guarantee period is 2 years as from the time of delivery.
2. All spare parts except motor components are under warranty.
3. If the goods break down during guarantee period, the time spent for maintenance will be added to guarantee period. Maintenance period is 30 days at most. 30 days begin with the notice to a service station. If there is no service station, 30 days begin with the notice to the seller, dealer, agency, agent, importer or manufacturer of the goods.
4. If production fault occurs during guarantee period; the cost of new spare part and labor will not be claimed from the customer.
5. If a fault occurs because of not using or assembling according to the instructions given in user manual, goods will be out of guarantee.

UNIT TYPE

SERIAL NO


ENEKO Havalandırma ve İsi Ekonomisi
Sistem Teknolojileri Makina San. ve Tic. A.S.
10049 Sokak No:4 İAOSB Cigli/İZMİR
Tel: 0.232.328 20 80
Web Address: www.eneko.com.tr


SIGNATURE:




www.eneko.com.tr

ISTANBUL

 Cevizli District, Zuhul Avenue, Fusun Street, Ritim Istanbul A5
Block Floor: 25 No: 137, 34846 Maltepe/Istanbul - TURKEY

 +90 216 455 29 60 /+90 216 455 29 61


 +90 216 455 29 62

 satis@eneko.com.tr

IZMIR

 10049 Street No: 4 I.A.O.S.B.
Cigli/Izmir - TURKEY

 +90 232 328 20 80

 +90 232 328 20 22

 info@eneko.com.tr

